

## CITY OF BURLINGTON CONSTRUCTION CONTRACT

This Construction Contract (“Contract”) is entered into by and between the City of Burlington, Vermont (“the City”), and PC Construction Company (“Contractor”), a Vermont corporation located at 193 Tilley Drive, South Burlington, VT 05403.

Contractor and the City agree to the terms and conditions of this Contract.

### 1. DEFINITIONS

The following terms shall be construed and interpreted as follows:

- A. **“Contract Documents”** means all the documents identified in Section 4 (Scope of Work) of this Contract.
- B. **“Effective Date”** means the date on which this Contract is approved and signed by the City, as shown on the signature page.
- C. **“Party”** means the City or Contractor and **“Parties”** means the City and Contractor.
- D. **“Project”** means the Memorial Auditorium Roof Structure Stabilization.
- E. **“Work”** means the services described in Section 5 (Payment for Services) of this Contract, along with the specifications contained in the Contract Documents as defined in Section 4 (Scope of Work) below.

### 2. RECITALS

- A. **Authority.** Each Party represents and warrants to the other that the execution and delivery of this Contract and the performance of such Party’s obligations have been duly authorized.
- B. **Consideration.** The Parties acknowledge that the mutual promises and covenants contained herein and other good and valuable consideration are sufficient and adequate to support this Contract.
- C. **Purpose.** The City seeks to employ the Contractor to perform the work required for stabilization of Substandard roof purlins at Memorial Auditorium.

### 3. EFFECTIVE DATE & TERM

- A. **Effective Date.** This Contract shall not be valid or enforceable until the Effective Date. The City shall not be bound by any provision of this Contract before the Effective Date and shall have no obligation to pay Contractor for any performance or expense incurred before the Effective Date or after the expiration or termination of this Contract.

**B. Term.** This Contract and the Parties' respective performance shall commence on the Effective Date and expire on June 1, 2023 or upon the satisfaction of the City, unless sooner terminated as provided herein.

#### 4. SCOPE OF WORK

The Contractor shall perform the services listed in Attachments A (Request for Proposals) and B (Contractor's Response to Request for Proposals).

#### 5. PAYMENT FOR SERVICES

**A. Amount.** The City shall pay the Contractor for completion of the Work in accordance with Attachment B (Contractor's Response to Request for Proposals).

Contractor agrees to accept this payment as full compensation for performance of all services and expenses incurred under this Contract.

**B. Payment Schedule.** The City shall pay the Contractor in the manner and at such times as set forth in the Contract Documents. The City seeks to make payment within thirty days of receipt of an invoice and any backup documentation requested under subsection D (Invoice) below.

**C. Maximum Limiting Amount.** The total amount that may be paid to the Contractor for all services and expenses under this Contract shall not exceed the maximum limiting amount of \$87,925. The City shall not be liable to Contractor for any amount exceeding the maximum limiting amount without duly authorized written approval.

**D. Invoice.** Contractor shall submit one copy of each invoice, including rates and a detailed breakdown by task for each individual providing services, and backup documentation for any equipment or other expenses to the following:

Kim Bleakley  
Burlington Parks, Recreation & Waterfront  
645 Pine Street  
Burlington, VT 05401  
[kbleakley@burlingtonvt.gov](mailto:kbleakley@burlingtonvt.gov)

The City reserves the right to request supplemental information prior to payment. Contractor shall not be entitled to payment under this Contract without providing sufficient backup documentation satisfactory to the City.

#### 6. SECTION & ATTACHMENT HEADINGS

The article and attachment headings and throughout this Contract are for the convenience of City and Contractor and are not intended nor shall they be used to construe the intent of this

Contract or any part hereof, or to modify, amplify, or aid in the interpretation or construction of any of the provisions hereof.

## **7. CONTRACT DOCUMENTS & ORDER OF PRECEDENT**

**A. Contract Documents.** The Contract Documents are hereby adopted, incorporated by reference, and made part of this Contract. The intention of the Contract Documents is to establish the necessary terms, conditions, labor, materials, equipment, and other items necessary for the proper execution and completion of the Work to ensure the intended results.

**The following documents constitute the Contract Documents:**

**Attachment A: Request for Proposals dated September 28, 2022**

**Attachment B: Contractor's Response to Request for Proposals dated October 19, 2022 and Clarifications dated October 25, 2022**

**Attachment C: Burlington Standard Contract Conditions for Construction Contractors**

**Attachment D: Burlington Livable Wage Ordinance Certification**

**Attachment E: Burlington Outsourcing Ordinance Certification**

**Attachment F: Burlington Union Deterrence Ordinance Certification**

**Attachment G: Contractor's Certificate of Insurance**

**B. Order of Precedent.** To the extent a conflict or inconsistency exists between the Contract Documents, or provisions therein, then the Contract takes precedent. Any Invitation for Bids, Additional Contract Provisions, and the City Ordinance Certifications shall prevail over any inconsistency with the Contractor's Scope of Work and Cost Proposal.

**8. [Reserved]**

— Signatures follow on the next page —

**SIGNATURE**

Persons signing for the Parties hereby swear and affirm that they are authorized to act on behalf of their respective Party and acknowledge that the other Party is relying on their representations to that effect.

**Contractor**  
**PC Construction Company**

By: \_\_\_\_\_  
Name & Signature

Date: \_\_\_\_\_

**City of Burlington**  
**Department of Parks, Recreation and Waterfront**

By: \_\_\_\_\_  
Cindi Wight  
Director

Date: \_\_\_\_\_

**Attachment A:  
Request for Proposals dated September 28, 2022**

DRAFT

**CITY OF BURLINGTON  
REQUEST FOR PROPOSALS**

**Issued: September 28, 2022**

**Due: October 19, 2022**

**I. PROJECT BACKGROUND**

The City is seeking a contractor(s) to complete structural stabilization at the roof framing of Memorial Auditorium. This historic building is located at 250 Main Street in Burlington, VT. The City will provide a building permit at no cost to the contractor(s) for this project. Parking is the responsibility of the contractor. Custom parking arrangements may be available if scheduled. Work shall be completed as soon as possible.

**II. SCOPE OF WORK**

The City is looking for stabilization of substandard roof purlins per the attached plans and specifications. Engineers have identified twenty-three locations where stabilization is required. There are an additional eighteen locations where assessment was not possible at the time of analysis and must be assessed by the selected contractor in partnership with the Structural Engineer and City personnel to determine if stabilization is required.

**III. RESPONSE FORMAT**

Contractors are encouraged to be concise. All proposals must include, but are not limited to the following:

- a) Letter of Interest.
- b) Completed and signed Bid Form (Exhibit C)
- c) Signed and notarized certificates of compliance in Exhibits G, H & I.
- d) A brief description of your firm's history and experience with structural stabilization in historic structures. If your firm intends to partner with another company, also provide pertinent information on the sub consultant.
- e) A work history of up to three (3) related projects showing for each:
  - Name, address and phone number for each client.
  - Brief project description.
  - Statement as to whether project was completed on time and within budget.

**IV. CONTRACTOR SELECTION**

A. Criteria: Proposals shall be evaluated based on the criteria listed below:

1. Priority assigned to the project and current workload of the firm with particular reference to the personnel and other resources being proposed (Note: Capacity to complete work in an efficient timeframe will be critical);
2. Past performance record and relevant experience;

3. Approach to project to complete in timeline;
4. Quality of work, timeliness and experience; and Financial responsibility of the firm.\*

Each General Contractor shall respond to evaluation criteria items 1 through 5 in a concise and easily identifiable manner. Information shall be utilized in the final selection decision.

\*The firm must agree to carry professional liability insurance including errors and omissions in an amount not less than \$1,000,000. (See additional insurance requirements in Exhibit F: Burlington Standard Contract Conditions.)

**B. Evaluation Criteria Assigned Weight:**

1. Total Project Cost 35%
  2. Qualifications 30%
  3. Schedule 35%
- TOTAL WEIGHT 100%

Proposals will be reviewed and evaluated by City staff based on the information provided. Additional information may be requested prior to final selection.

- C. Rejection of Proposals:** The City reserves the right to reject any or all proposals, to negotiate with one or more parties, or to award the contract in the City's best interests, including proposed contractor's schedule. The City reserves the right to re-advertise for additional proposals and to extend the deadline for submission of the proposals.

No proposal will be considered accepted until all necessary City authorizations, including those required by Board of Finance and City Council if necessary, have been received and an agreement is executed by both parties.

**V. SUBMISSIONS**

**A. Deadline for Receipt of Proposals:** All proposals in response to this Request for Proposals (RFP) must be received by email to the point of contact no later than 12:00 p.m. on the above due date. The proposal shall be marked "Memorial Roof Structure Stabilization". Late proposals will not be accepted under any circumstances. Electronic proposals are preferred as long as they are received by the point of contact by the required deadline. It is the responsibility of the entity submitting replies and proposals to ensure that the point of contact has received a completed proposal by the required deadline.

**B. Answers to Questions and Revisions to Request for Proposal:** Any revisions, addendums and answers to questions received by the question deadline will be sent to consultants who directly received this proposal via email. In addition, revisions will be posted on the City's RFP web page <http://burlingtonvt.gov/RFP/>. It is advised that consultants sign up for the GovDelivery notification so that they will be notified of any changes.

Point of Contact:

Samantha Dunn  
Assistant Director for Community Works  
Community & Economic Development Office  
[sdunn@burlingtonvt.gov](mailto:sdunn@burlingtonvt.gov)  
(802) 829-6385

## **VI. EXHIBITS**

- Exhibit A: Plans and Specifications
- Exhibit B: Existing Conditions Photos
- Exhibit C: Bid Form
- Exhibit D: Contractor Pre Qualification Application - Omitted (N/A)
- Exhibits E through I are redundant with Contract Attachments and have been omitted.

Bid documents include this main body of the request for proposals and all exhibits.

## **VII. CONTRACTING**

The contractor must qualify as an independent contractor and, prior to being awarded a contract, must apply for registration with the Vermont Secretary of State's Office to do business in the State of Vermont, if not already so registered. The registration form may be obtained from the Vermont Secretary of State, 128 State Street, Montpelier, VT 05633-1101, PH: 802-828-2363, Toll-free: 800-439-8683; Vermont Relay Service – 711; web site: <https://www.sec.state.vt.us/>. The contract will not be executed until the consultant is registered with the Secretary of State's Office.

Prior to beginning any work, the consultant shall obtain Insurance Coverage in accordance with the Burlington Contract Conditions (Exhibit F in this RFP). The certificate of insurance coverage shall be documented on forms acceptable to the City.

## **VIII. AGREEMENT REQUIREMENTS**

The selected consultant will be required to execute a contract with the City on the terms and conditions required by the City, including but not limited to those in the Burlington Contract Conditions (Exhibit F) and the attached Draft Agreement. No proposal will be considered accepted until all necessary City authorizations—including those required by Board of Finance and City Council if necessary—have been received and an agreement is executed by both parties.

## **IX. LIMITATIONS OF LIABILITY**

The City assumes no responsibility or liability for the response to this Request for Proposals.

**X. COSTS ASSOCIATED WITH PROPOSAL**

Any costs incurred by any person or entity in preparing, submitting, or presenting a proposal are the sole responsibility of that person or entity, including any requests for additional information or interviews. The City will not reimburse any person or entity for any costs incurred prior to the issuance of the contract.

**XI. INDEMNIFICATION**

Any party responding to this Request for Proposals is acting in an independent capacity and not as an officer or employee of the City. Any party responding to this Request for Proposals will be required to indemnify, defend, and hold harmless the City, its officers, and employees from all liability and any claims, suits, expenses, losses, judgments, and damages arising as a result of the responding party's acts and/or omissions in or related to the response.

**XII. REJECTION OF PROPOSALS**

The City reserves the right to reject any or all proposals, to negotiate with one or more parties, or to award the contract to the proposal the City deems will meet its best interests, even if that proposal is not the lowest bid. The City reserves the right to re-advertise for additional proposals and to extend the deadline for submission of the proposals. This Request for Proposals in no way obligates the City to award a contract.

**XIII. OWNERSHIP OF DOCUMENTS**

Any materials submitted to the City in response to this Request for Proposals shall become the property of the City unless another arrangement is made by written agreement between the City and the responding party. The responding party may retain copies of the original documents.

**XIV. DUTY TO INFORM CITY OF BID DOCUMENT ERRORS**

If a bidder knows, suspects, or has reasonable cause to believe, that an error or omission exists in any bid documents, including but not limited to unit prices and rate calculations, the bidder shall immediately give the City written notice thereof. Contractor shall not cause or permit any work to be conducted that may related to the error or omission without first receiving written acknowledgment from the City that City representatives understand the possible error or omission and have approved the requested modifications to the bid or contract documents or that the contractor may proceed without any modification being made to the bid or contract documents.

**XV. PUBLIC RECORDS**

Any and all records submitted to the City, whether electronic, paper, or otherwise recorded, are subject to the Vermont Public Records Act. The determination of how those records must be handled is solely within the purview of City. All records the responding party considers to be trade secrets, as that term is defined by subsection 317(c)(9) of the Vermont Public Records Act, or that the responding party otherwise seeks to have the City consider as exempt must be identified clearly and specifically at the time of submission. It is not sufficient to merely state generally that a proposal is proprietary, contains a trade secret, or is otherwise exempt. Particular records, pages, and sections which are believed to be exempt must be specifically identified as such and must be separated from other records with a convincing explanation and rationale sufficient to justify each exemption from release consistent with Section 317 of Title 1 of the

Vermont Statutes Annotated.

**XVI. PUBLIC HEALTH EMERGENCIES**

Bidders are advised that public health emergencies, as declared by the City, the State of Vermont, or the Federal Government, may introduce significant uncertainty into the project, including disruption of timelines or revised practices. Contractors shall consider public health emergencies as they develop project schedules and advance the work.

If a public health emergency is declared, the City will not be responsible for any delays related to the sequence of operations or any expenses or losses incurred as a result of any delays. Any delays related to public emergencies will be excusable, but will not be compensable.

## **Exhibit A: Plans and Specifications**

EXISTING WOOD ROOF BEAM, TYP

REPAIR CALLOUT, SEE LEGEND

EXISTING STEEL TRUSS, TYP

EXISTING TRUSS BRACING, TYP

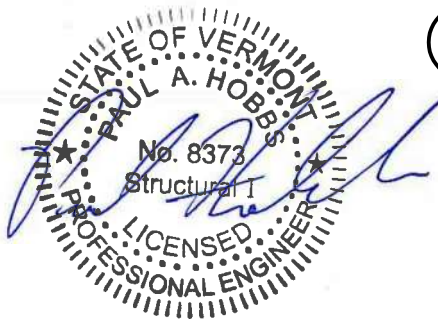
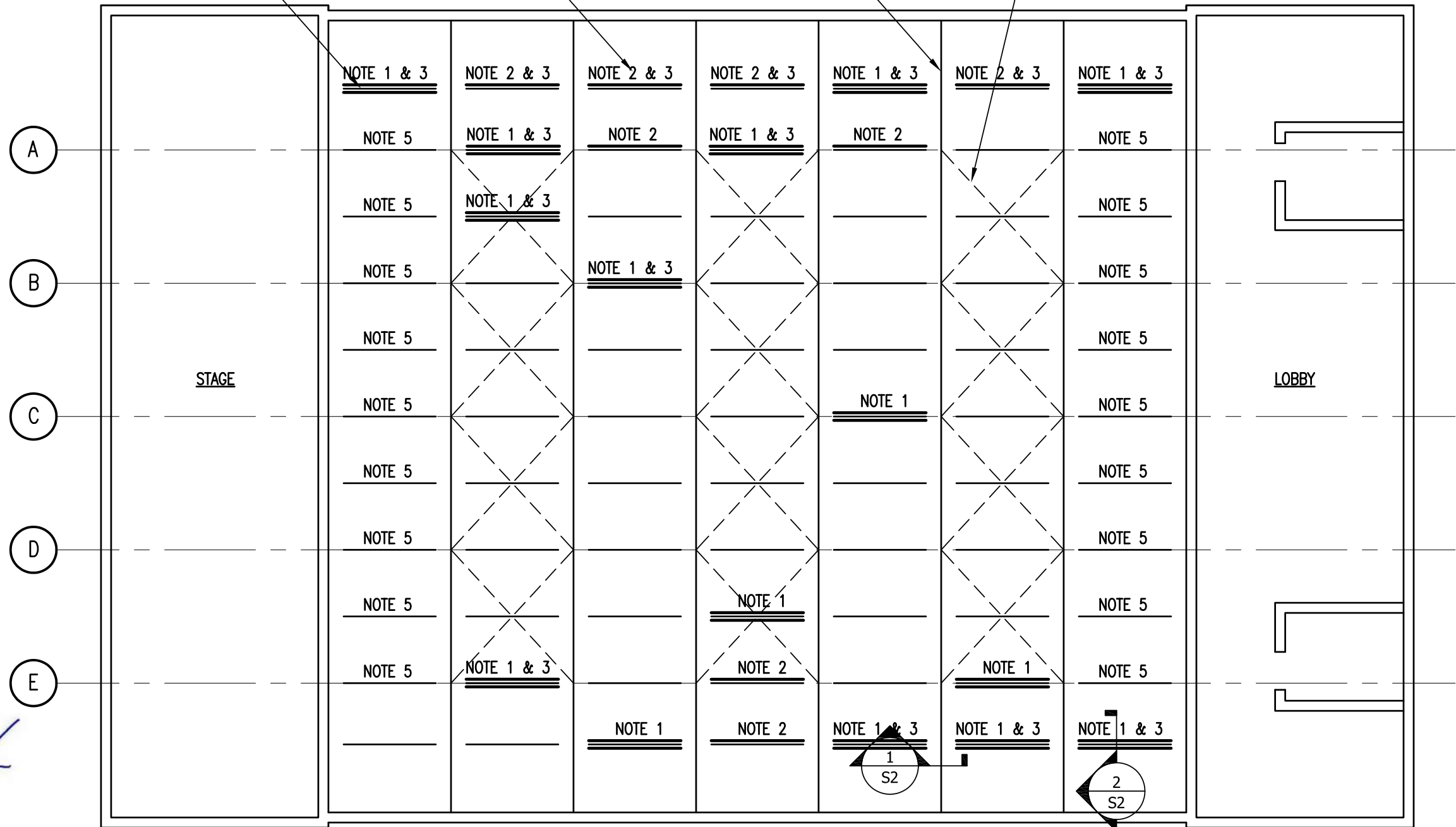

### ROOF BEAM REINFORCING PLAN

1



NOT TO SCALE

**PLAN NOTES:**

- 1) SISTER BOTH SIDES OF BEAM PER DETAIL 1/S2.
- 2) SISTER ONLY NORTH SIDE OF BEAM PER DETAIL 1/S2.
- 3) STRIP PAINT AND SOFT OR ROTTED WOOD. PRIME AND PAINT PER OWNER STANDARD.
- 4) REMOVAL AND REATTACHMENT OF PIPE SPRINKLER PIPE HANGERS MAY BE NECESSARY TO PERFORM REINFORCING. CONTRACTOR TO SUBMIT HANGER TO BEAM CONNECTION DETAIL AND DEVICE IF DIFFERENT THEN EXISTING. CONTRACTOR TO INCLUDE ESTIMATE OF NUMBER OF CONNECTIONS TO BE REWORKED IN BID. WE HAVE NOT TABULATED THIS QUANTITY HERE.
- 5) NOT ACCESSIBLE FOR ASSESSMENT.

**ENGINEERING VENTURES PC**  
 208 Flynn Avenue, Suite 2A Burlington, VT 05401  
 tel. 802.863.6225 • fax 802.863.6306  
 85 Mechanic Street, Suite 350A, Lebanon, NH 03766  
 tel. 603.442.9333 • fax 603.442.9331  
 www.engineeringventures.com

**ROOF BEAM EVALUATION AND REINFORCING**  
**MEMORIAL AUDITORIUM**  
**BURLINGTON PARKS & RECREATION DEPT**

|                           |                              |
|---------------------------|------------------------------|
| Checked By:<br><b>PAH</b> | Scale:<br><b>AS NOTED</b>    |
| Drawn By:<br><b>MRE</b>   | Project No.:<br><b>15824</b> |
| Date:<br><b>9/26/2022</b> | Drawing No.:<br><b>S1</b>    |

# BASIS OF DESIGN

- 2012 VERMONT FIRE AND SAFETY CODE
- DEAD LOAD: 10psf (SUPPORTED BY ROOF BEAMS)
- SNOW LOAD: Pg: 40psf, Ce: 1, I: 1, Ct: 1, Pf: 40psf

# NOTES

## GENERAL NOTES

- DIMENSIONS, ELEVATIONS, MEMBER SIZES, AND DETAILS OF ALL EXISTING STRUCTURES HAVE BEEN EXTRACTED FROM RECORD DRAWINGS AND/OR FIELD MEASUREMENTS. THE CONTRACTOR SHALL VERIFY ALL FIELD CONDITIONS AND DIMENSIONS PRIOR TO DETAILING, FABRICATION, OR CONSTRUCTION. ANY DEVIATIONS FOUND IN THE FIELD FROM WHAT IS SHOWN ON THE DRAWINGS, SHALL BE REPORTED IN WRITING TO THE ENGINEER PRIOR TO FABRICATION OR CONSTRUCTION.
- IN THE CASE OF A CONFLICT BETWEEN THE DRAWINGS, SPECIFICATIONS OR NOTES ON THE DRAWINGS, THE ENGINEER SHALL BE NOTIFIED TO RESOLVE THE DISCREPANCY.
- IF DEVIATIONS OR CHANGES FROM TO THE APPROVED DESIGN AND "RELEASED FOR PRODUCTION" SHOP DRAWINGS ARE REQUIRED DUE TO INTERFERENCES, FABRICATION ERRORS, OR OTHER CAUSES, THE ENGINEER SHALL BE NOTIFIED. SUBMIT ANY PROPOSED CHANGES TO THE ENGINEER FOR REVIEW PRIOR TO MAKING CHANGES.
- DO NOT FIELD CUT OR ALTER STRUCTURAL MEMBERS WITHOUT APPROVAL OF ENGINEER.

## MATERIALS

- LAMINATED VENEER LUMBER (LVL):  
LVL FRAMING SHALL BE LAMINATED DOUGLAS FIR OR SOUTHERN PINE (GP LAM BY GEORGIA PACIFIC OR MICROLAM BY TRUS-JOIST OR EQUAL) MEETING THE FOLLOWING MINIMUM ALLOWABLE STRESS CRITERIA:  
 FB (BENDING STRESS) = 2600 PSI  
 FV (HORIZ. SHEAR STRESS) = 285 PSI  
 E (MODULUS OF ELASTICITY) = 1,900,000 PSI  
 FC (COMPRESSION PERPENDICULAR TO GRAIN) = 750 PSI

## FINISH

- COORDINATE PAINTING REQUIREMENTS WITH OWNER BASED ON EXISTING STANDARDS.

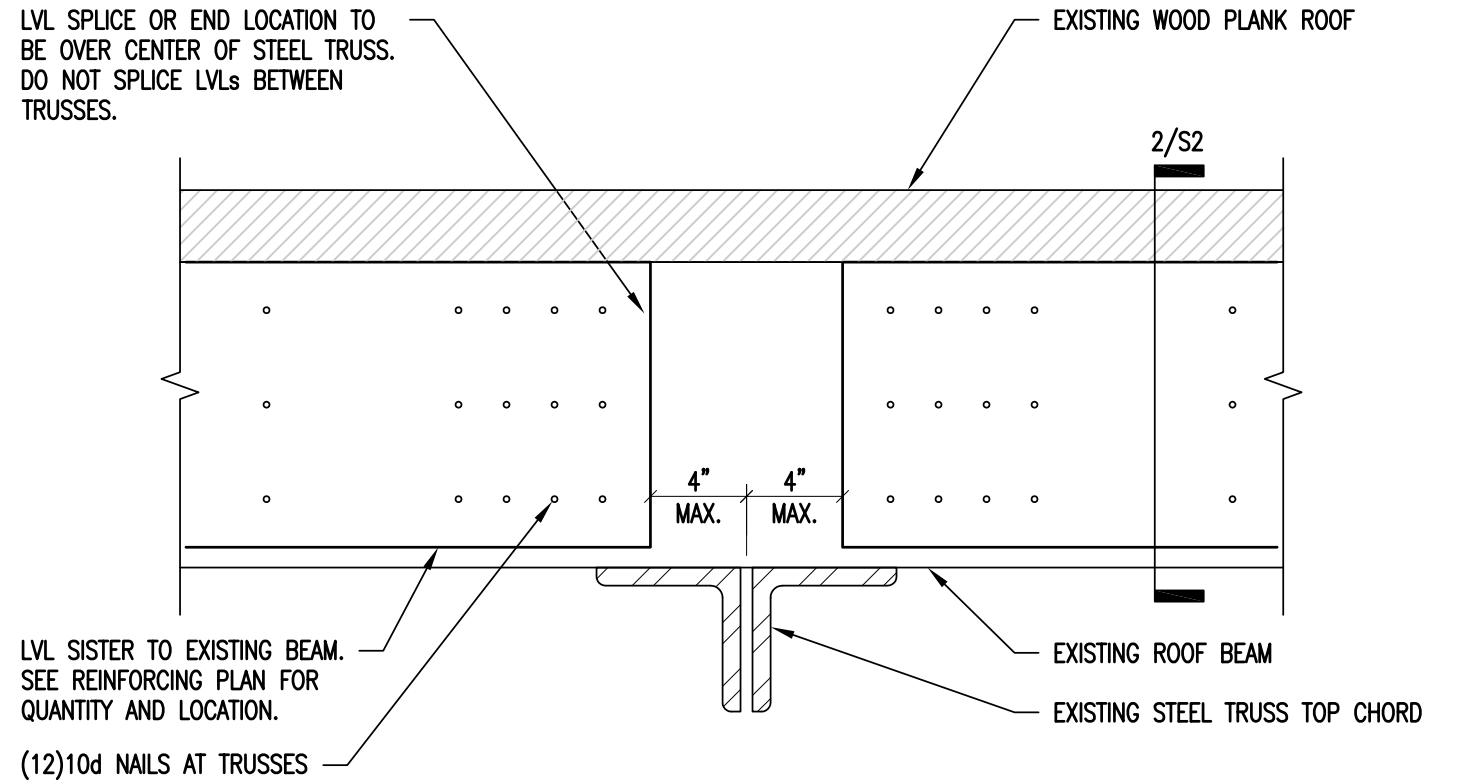

REINFORCED BEAM DETAIL AT STEEL TRUSS

1 1/2"=1'-0"

1

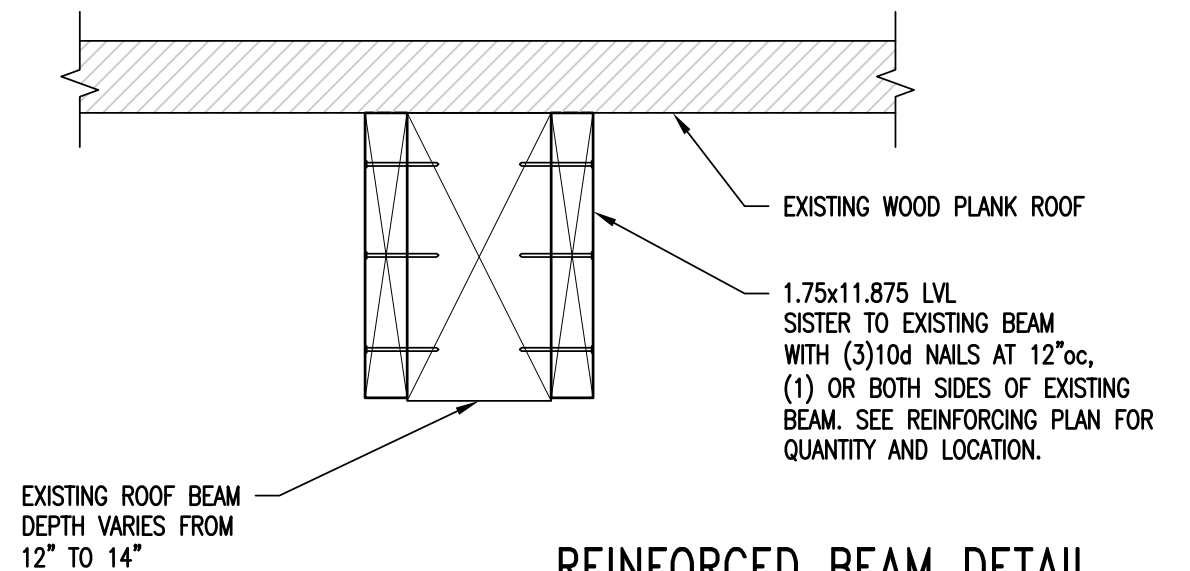

REINFORCED BEAM DETAIL

1 1/2"=1'-0"

2

|   |  |                           |                              |
|---|--|---------------------------|------------------------------|
| <p><b>ENGINEERING VENTURES PC</b><br/>208 Flynn Avenue, Suite 2A Burlington, VT 05401<br/>tel. 802.863.6225 • fax 802.863.6306<br/>85 Mechanic Street, Suite 350A, Lebanon, NH 03766<br/>tel. 603.442.9333 • fax 603.442.9331<br/>www.engineeringventures.com</p> | <p><b>ROOF BEAM EVALUATION AND REINFORCING</b></p> <p><b>MEMORIAL AUDITORIUM</b><br/><b>BURLINGTON PARKS &amp; RECREATION DEPT</b></p> | Checked By:<br><b>PAH</b> | Scale:<br><b>AS NOTED</b>    |
|   |  | Drawn By:<br><b>MRE</b>   | Project No.:<br><b>15824</b> |
|   |  | Date:<br><b>9/26/2022</b> | Drawing No.:<br><b>S2</b>    |

**Exhibit B: Existing Conditions Photos**



100 LBS.





















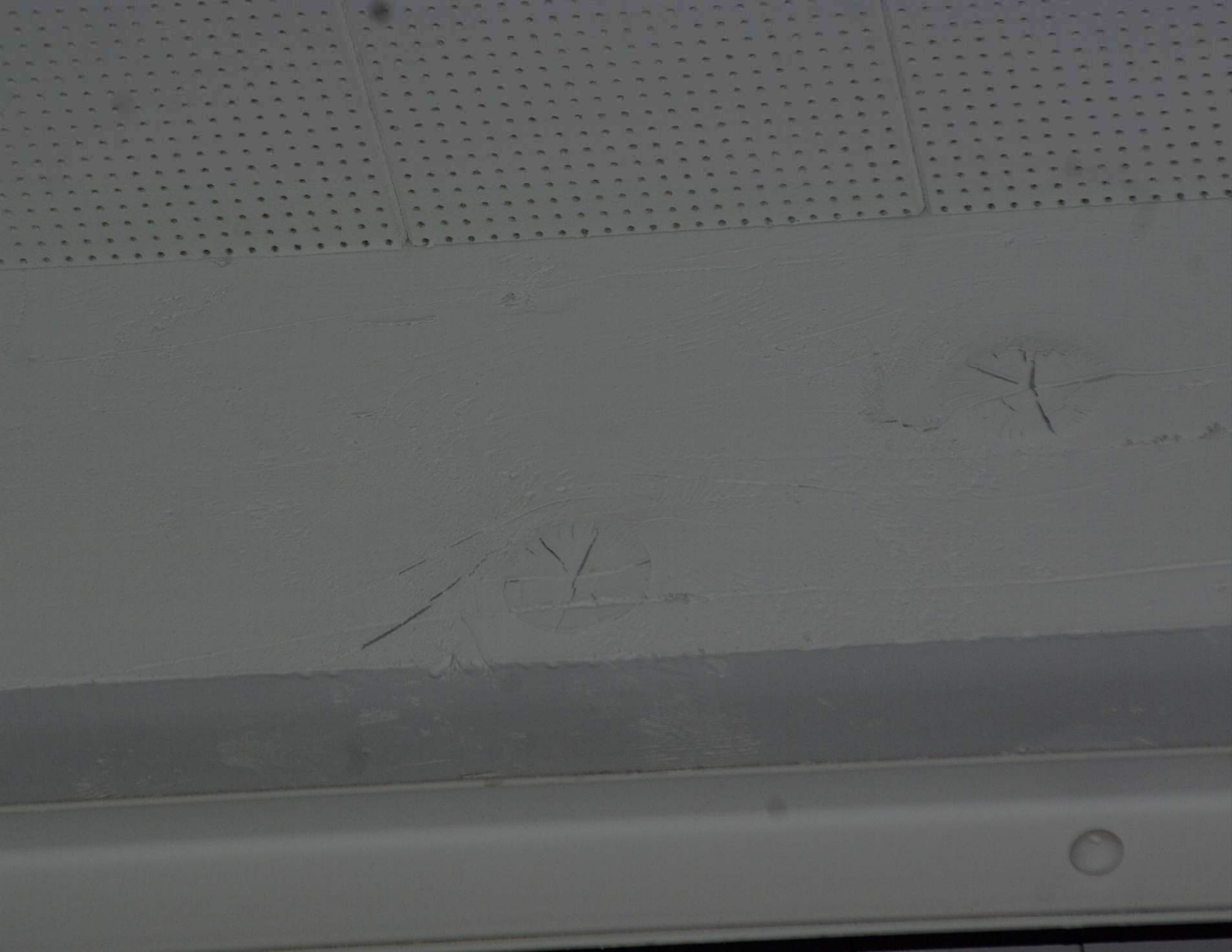





## **Exhibit C: Bid Form**

**BID FORM**

**PROJECT: Memorial Auditorium Roof Framing Stabilization**

Contractor: \_\_\_\_\_ Address: \_\_\_\_\_

Contact: \_\_\_\_\_ Telephone/Email: \_\_\_\_\_

Estimated Start Date: \_\_\_\_\_ Estimated End Date: \_\_\_\_\_

**BASE BID**

| ITEM                                       | UNIT     | SUBTOTAL |
|--|----------|----------|
| Stabilization of substandard roof purlins. | Lump sum | \$       |
|  |          |          |

TOTAL BASE BID: \$ \_\_\_\_\_

**UNIT COST FOR ADDITIONAL REINFORCING**

| ITEM                                | UNIT    | SUBTOTAL |
|-------------------------------------|---------|----------|
| Sister both sides of beam           | Per LVL | \$       |
| Sister single side of beam          | Per LVL | \$       |
| Strip paint and soft or rotted wood | Per LVL | \$       |

**Note: This project is tax exempt. Prices quoted shall not include sales tax.**

BY SIGNING THIS BID FORM, THE CONTRACTOR AGREES TO ABIDE BY ALL SPECIFICATIONS AND CONDITIONS IN THE CONTRACT DOCUMENTS, INCLUDING THE FOLLOWING:

- 1) Perform work in accordance with applicable rules, regulations, codes, and ordinances of local, state and federal authorities;
- 2) Obtain and pay for necessary permits, licenses and certificates and give notices as required during the performance of the work; and

---

SIGNATURE & DATE

---

NAME

---

TITLE

WITH THIS BID, THE CONTRACTOR MUST INCLUDE SIGNED CERTIFICATES OF COMPLIANCE WITH LIVABLE WAGE, OUTSOURCING AND UNION DETERRENCE. THESE FORMS ARE INCLUDED IN EXHIBITS G, H, AND I.

**Attachment B:  
Contractor's Response to Request for Proposals dated October 19, 2022 and  
Clarifications dated October 25, 2022**

DRAFT



# City of Burlington Memorial Roof Structure Stabilization

Proposal for Construction Services

October 19, 2022

OCTOBER 19, 2022

# TABLE OF CONTENTS

---

## Letter of Interest

**SECTION 1** Bid Form (Exhibit C) & Schedule

**SECTION 2** Signed and notarized Exhibits G, H & I

**SECTION 3** About PC Construction's Special Project Group

**SECTION 4** Related Projects



**BUILDING STRONGER, TOGETHER**

**Special Project Group**  
72 San Remo Drive  
South Burlington, VT 05403  
802.658.4100  
pcconstruction.com

October 19, 2022

Samantha Dunn  
Assistant Director for Community Works  
Community & Economic Development Office  
149 Church Street  
Burlington, VT 05401  
sdunn@burlingtonvt.gov

Re: Memorial Roof Structure Stabilization  
PC Project Number SPGVT20220030

Dear Ms. Dunn:

On behalf of the entire PC Construction team, I would like to thank you for the opportunity to provide construction services to support your project. The enclosed bid is detailed on the provided Bid Form (Exhibit C). In response to the RFP's Section IV. Contractor Selection, A. Criteria, we have provided a concise to those items here to assist in your selection process:

**A.1. Priority assigned to the project and current workload of the firm with particular reference to the personnel and other resources being proposed (Note: Capacity to complete work in an efficient timeframe will be critical).**

Our firm has the capacity to undertake and deliver this project. SPG has positioned itself with sufficient management, craftworker and equipment resources specifically for these stabilization projects. The team we have proposed has sufficient availability and has experience on scope of similar nature at the Waterbury State Office Complex. Additionally, the projected construction start date of mid-December aligns well with the current assignments they are completing this fall.

**A.2. Past performance record and relevant experience.**

In 1958, the Pizzagalli family started a small Vermont masonry business built on a foundation of quality and excellence. Their dream started small, but the company quickly expanded with a focus on commercial, industrial and institutional building projects, becoming Vermont's largest construction company by 1964.

With a dedicated team and an exceptional commitment to project excellence, strong client partnerships emerged, many which have spanned 50 years and counting, including The University of Vermont Medical Center, the State of Vermont, the University of Vermont and Champlain College. Ultimately, what began as a dream and a lot of grit and determination, grew over six decades into a thriving 100% employee-owned construction firm that is consistently ranked among the top 300 largest construction firms in the nation.

PC has continued to be very involved with Burlington-area construction projects including for the University of Vermont, Hotel Vermont, Hilton Burlington and the UVM Medical Center. PC's Special Project Group (SPG) has direct experience working with the City of Burlington, including improvements to the basement floor of Fire Dept #1. The project involved

the removal of existing slab, installation of drainage and sump put and replacement of concrete floor slab. This project was completed on time, within budget, and without interruption to the operational facility. Additional relevant experience is also provided, as requested, in Section 4 of this proposal.

We would also like to note of PC's long history with Engineering Ventures (EV). PC has completed many local projects with EV including the Waterbury State Office Complex and a complex structural renovation at UVM's Gutterson arena. Both of these projects can also be found in Section 4.

### A.3. Approach to project to complete in timeline.

At this early bidding stage, we have already begun to plan the timeline for the project. As such, we have included an early project schedule to communicate the efficient approach and coordination of phases to complete the project on time. Once PC is selected and contract documents are reviewed, we will finalize our project approach and communicate this with your team to begin work promptly. We have reviewed the conditions at the site and tailored our estimate and schedule to address the challenges of access to the areas above the balconies. PC prioritizes safety and plans for its execution in the estimating stages of a project. We plan to temporarily remove portions of the balcony seating to allow for the set-up of an OSHA approved scaffolding system in order to access the beams above. At the adjacent areas we would plan to utilize multiple electric scissor lifts to access the beam stabilization locations.

### A.4. Quality of work, timeliness and experience; and Financial responsibility of the firm.

PC's quality of work is driven by the strength of our quality management process and is proven to provide superior quality assurance and quality control in achieving success on construction projects. From the very beginning and continuing through construction and turnover, the entire process focuses on quality, accuracy and integrity of the work. On projects of this nature we work collaboratively with the engineer of record to ensure that the intent of the design is met, making any necessary changes as field conditions are verified or found to differ.

Timeliness: As your general manager, the project schedule is our responsibility to manage and update throughout the construction phase. Our team has already put a base together and related to schedule, will communicate any updates effectively throughout the stabilization work.

Financial Responsibility: PC has the company resources, financial capacity, and highly qualified, experienced construction professionals to effectively manage and complete the Memorial Roof Structural Stabilization project safely, within budget and on time. We have developed exceptionally strong relationships with our surety and insurance companies based on sound risk management, successful project performance, and associations that span 60 years.

As always, it has been a pleasure working with you and your team on past projects and we look forward to assisting you on this one. We are available at your convenience to review our bid package and answer any questions you may have. Best wishes for a successful project.

Again, thank you for this opportunity. We are excited to bring a local and highly experienced team to the City of Burlington for another successful project. Should you have any questions, please contact me at 802.598.6307 or [ttremblay@pcconstruction.com](mailto:ttremblay@pcconstruction.com).

October 19, 2022  
Memorial Roof Structural Stabilization  
Page 2

Sincerely,

A handwritten signature in black ink, appearing to read "Travis Tremblay". The signature is fluid and cursive, with the first name being more prominent.

Travis Tremblay  
Project Manager

cc: Justin Reed, PC Construction  
Colin Menard, PC Construction

**Exhibit C: Bid Form**

**BID FORM**

**PROJECT: Memorial Auditorium Roof Framing Stabilization**

Contractor: PC Construction Company Address: 193 Tilley Drive, South Burlington, VT 05403

Contact: Chester J. Layman Telephone/Email: 802.651.1379

Estimated Start Date: 12/18/22 Estimated End Date: 1/5/23

**BASE BID**

| ITEM                                       | UNIT     | SUBTOTAL       |
|--|----------|----------------|
| Stabilization of substandard roof purlins. | Lump sum | \$<br>\$70,425 |
|  |          |                |

TOTAL BASE BID: \$ \$70,425

**UNIT COST FOR ADDITIONAL REINFORCING**

| ITEM                                | UNIT    | SUBTOTAL      |
|-------------------------------------|---------|---------------|
| Sister both sides of beam           | Per LVL | \$<br>\$1,575 |
| Sister single side of beam          | Per LVL | \$<br>\$855   |
| Strip paint and soft or rotted wood | Per LVL | \$<br>\$760   |

**Note: This project is tax exempt. Prices quoted shall not include sales tax.**

BY SIGNING THIS BID FORM, THE CONTRACTOR AGREES TO ABIDE BY ALL SPECIFICATIONS AND CONDITIONS IN THE CONTRACT DOCUMENTS, INCLUDING THE FOLLOWING:

- 1) Perform work in accordance with applicable rules, regulations, codes, and ordinances of local, state and federal authorities;
- 2) Obtain and pay for necessary permits, licenses and certificates and give notices as required during the performance of the work; and

10/19/2022  
SIGNATURE & DATE

Chester J. Layman

NAME

Vice President

TITLE

WITH THIS BID, THE CONTRACTOR MUST INCLUDE SIGNED CERTIFICATES OF COMPLIANCE WITH LIVABLE WAGE, OUTSOURCING AND UNION DETERRENCE. THESE FORMS ARE INCLUDED IN EXHIBITS G, H, AND I.



**BUILDING STRONGER, TOGETHER**

193 Tilley Drive  
South Burlington, VT 05403  
802.658.4100  
pcconstruction.com

**100% EMPLOYEE OWNED**

## **Memorial Roof Structure Stabilization Clarifications**

1. Our proposal is based on a mutually beneficial contract terms and conditions.
2. Our proposal specifically excludes all costs associated with surveying, design, and/or legal fees.
3. Our proposal does not include any costs associated with Owner's Contingency.
4. Our proposal specifically excludes the testing, handling, and disposal of hazardous containing materials.
5. Our proposal excludes costs associated with performance and payments bonds.
6. Our proposal is valid for 15 days from the date of submission due to the highly volatile market.
7. Our proposal excludes painting of existing beams outside of those noted on the drawings.
8. Our proposal includes the painting of the new LVL's to be installed as part of this work.
9. Our proposal includes removal of construction debris generated by the performance of this scope of work and excludes cleaning of the space or removal of preexisting debris.
10. Our proposal excludes builders risk insurance and assumes the City would maintain current insurance coverage on the building during construction.



**Exhibit G: Burlington Livable Wage Ordinance Certification**



**Exhibit H: Burlington Outsourcing Ordinance Certification**

Certification of Compliance with the City of Burlington's Outsourcing Ordinance

I, Chester J. Layman, on behalf of  
PC Construction Company (Contractor) and in connection with the  
Memorial Auditorium Roof Framing Stabilization

\_\_\_\_\_ [project], hereby certify under oath that (1) Contractor shall comply with the City of Burlington's Outsourcing Ordinance (Ordinance §§ 21-90 – 21-93); (2) as a condition of entering into this contract or grant, Contractor confirms that the services provided under the above-referenced contract will be performed in the United States or Canada.

Dated at 193 Tilley Drive, South Burlington, Vermont this 19th day of October, 2022.

By:   
Duly Authorized Agent

Subscribed and sworn to before me:

  
Notary

Karyn Carstensen  
My commission expires January 31, 2023  
Credential # 157.0003965



**Exhibit I: Burlington Union Deterrence Ordinance Certification**

Certification of Compliance with the City of Burlington's  
Union Deterrence Ordinance

I, Chester J. Layman, on behalf of PC Construction Company  
(Contractor) and in connection with Memorial Auditorium Roof Framing Stabilization (City  
contract/project/grant), hereby certify under oath that PC Construction Company  
(Contractor) has not advised the conduct of any illegal activity, and it does not currently, nor will  
it over the life of the contract advertise or provide union deterrence services in violation of the  
City's union deterrence ordinance.

Dated at 193 Tilley Drive, South Burlington, Vermont this 19th day of October, 2022.

By: \_\_\_\_\_

  
Duly Authorized Agent

**SECTION 3****ABOUT PC CONSTRUCTION'S SPECIAL PROJECT GROUP**

---

**ABOUT PC CONSTRUCTION**

PC Construction was founded in South Burlington, Vermont, in 1958 by the Pizzagalli family. Over the next 64 years in operation, we have grown to become a local leader in Vermont and New England construction. We offer general contracting, construction management, design-build and preconstruction planning services for projects of all sizes.

Today, PC is Vermont's largest construction firm and 100% employee-owned. This means our owners are the same people who come to work at PC every day – our skilled craft professionals, project management teams and administrative staff. As employee-owners we focus on everything we build – from challenging buildings and facilities to critical infrastructure. Our commitment brings distinctive value to the special relationships with our client, design and trade partners. Everything we are building is from a unique perspective: Ownership, makes our services more focused, collaborative and personalized. We call this BUILDING STRONGER, TOGETHER.

**Special Projects Group (SPG)**

Our Special Projects Group (SPG) offers the vast construction experience, purchasing power and financial backing of PC, while specifically focusing on projects valued up to \$5 million. PC SPG has the experience and capability to complete projects in nearly any division of work, under any contract structure and with an agility that cannot be matched.

Over the past decade, SPG has completed nearly 2,000 individual projects totaling \$125 million, with 90% of the work for repeat customers and 60% self-performed by our own crews. The results speak for themselves.

**Structural Stabilization/Historical Renovations**

PC has extensive, award-winning experience in the restoration and preservation of historical buildings. Our projects include a variety of building uses; from historic mills and industrial buildings to institutional and residential facilities. A critical aspect of many projects of this nature is rehabilitating and ensuring the structural integrity of the building. The PC Special Projects Group has self-performed the structural stabilization on many of PC's larger projects, as well as having worked directly for various Owners around the region on projects of varied size. SPG has worked with Owners to meet their goals from both a cost and historic preservation perspective, often balancing the two priorities.

## SECTION 4 RELATED PROJECTS



### **Waterbury State Office Complex Historic Restoration**

Waterbury, VT | LEED Platinum with LEED Gold for the Central Plant

The historic restoration of the State Office Complex due to flood damage from Tropical Storm Irene, was the largest capital project ever undertaken by the State of Vermont. Scope of work included deconstruction of 355,000 square feet of flood-damaged structures and more than 100,000 square feet of renovations to 13 historic core buildings and flood-damage prevention measures with extensive site and infrastructure work.

Contact: Former BGS Project Manager Mike Stevens  
103 South Main Street, Waterbury VT 05676  
802.316.6702

The project was completed on-time and on-budget.



### **Stowe Electric Department – Moscow Mill Foundation Stabilization**

Stowe, VT

Foundation repairs to historic 1800's mill building in Stowe, Vermont. Scope included temporary shoring systems, excavation, concrete foundations, and steel brace frame installation working within the Little River.

Contact: Michael Lazorchak  
Stowe Electric Department, PO Box 190, Stowe, VT 05672  
802.253.7215

The project was completed on-time and on-budget.



### **The University of Vermont On-Campus Multipurpose Center Sequence 1**

Burlington, VT

The first sequence of a project to completely renovate the University of Vermont's Patrick-Forbush-Gutterson Athletic Complex. Project features included support of excavation systems and challenging structural renovations to the 60-year-old Gutterson Fieldhouse. The PC team worked very closely with Engineering Ventures on this scope of work.

Contact: Todd Merchant  
Marsh Hall, Suite 10 31 Spear Street, Burlington VT 05405  
802.656.3291

The project was completed on-time and on-budget.



**BUILDING STRONGER, TOGETHER**

PC Construction  
[pccconstruction.com](http://pccconstruction.com)

**100% EMPLOYEE OWNED**



**BUILDING STRONGER, TOGETHER**

193 Tilley Drive  
South Burlington, VT 05403  
802.658.4100  
pcconstruction.com

**100% EMPLOYEE OWNED**

## **Memorial Roof Structure Stabilization Clarifications Revised 10/25/22**

1. Our proposal is based on a mutually beneficial contract terms and conditions.
2. Our proposal specifically excludes all costs associated with surveying, design, and/or legal fees.
3. Our proposal does not include any costs associated with Owner's Contingency.
4. Our proposal specifically excludes the testing, handling, and disposal of hazardous containing materials.
5. Our proposal excludes costs associated with performance and payments bonds.
6. Our proposal is valid for 15 days from the date of submission due to the highly volatile market.
7. Our proposal excludes painting of existing beams outside of those noted on the drawings.
8. Our proposal includes the painting of the new LVL's to be installed as part of this work.
9. Our proposal includes removal of construction debris generated by the performance of this scope of work and excludes cleaning of the space or removal of preexisting debris.
10. Our proposal excludes builders risk insurance and assumes the City would maintain current insurance coverage on the building during construction.
11. As an option, we propose to include an allowance to address any structural concerns associated with the stability of the existing floor to support electric scissor lifts. This allowance of \$10,000 will be use don a Time and Materials basis to track costs associated with upgrades, temporary matting, and changes to means and methods currently spelled out in the project approach.
12. We propose an allowance of \$7,500 to perform access to the areas currently concealed by the sloped soffits. We would perform this work on a Time and Materials basis and in coordination with personnel from Engineering Ventures.

|                                      |                    |
|--------------------------------------|--------------------|
| Total base Bid:                      | \$70,425.00        |
| Access Enhancement Allowance:        | \$10,000.00        |
| <u>Exploratory Access Allowance:</u> | <u>\$ 7,500.00</u> |
| Total Proposed Contract Value:       | \$87,925.00        |

**Attachment C:  
Burlington Contractor Conditions for Construction Contracts**

DRAFT

**ATTACHMENT C:  
BURLINGTON STANDARD CONTRACT CONDITIONS  
FOR CONSTRUCTION CONTRACTORS**

1. **REGISTRATION:** The Contractor agrees to be registered with the Vermont Secretary of State's office as a business entity doing business in the State of Vermont at all times this contract is effective. This registration must be complete prior to contract execution.
  
2. **INSURANCE:** Prior to beginning any work, the Contractor shall obtain the following insurance coverage from an insurance company registered and licensed to do business in the State of Vermont and having an A.M. Best insurance rating of at least A-, financial size category VII or greater ([www.ambest.com](http://www.ambest.com)). The certificate of insurance coverage shall be documented on forms acceptable to the City. Compliance with minimum limits and coverage, evidenced by a certificate of insurance showing policies and carriers that are acceptable to the City, must be received prior to the Effective Date of the Contract. The insurance policies shall provide that insurance coverage cannot be canceled or revised without thirty (30) days prior notice to the City. If this Contract extends to more than one year, evidence of continuing coverage must be submitted to the City on an annual basis. Copies of any insurance policies may be required. Each policy (with the exception of professional liability and worker's compensation) shall name the City as an additional insured for the possible liabilities resulting from the Contractor's actions or omissions. The liability insurance furnished by the Contractor is primary and non-contributory for all the additional insured.

The Contractor is responsible to verify and confirm in writing to the City that: (i) all subcontractors must comply with the same insurance requirements as the Contractor; (ii) all coverage shall include adequate protection for activities involving hazardous materials; and (iii) all work activities related to the Contract shall meet minimum coverage and limits.

No warranty is made that the coverage and limits listed herein are adequate to cover and protect the interests of the Contractor for the Contractor's operations. These are solely minimums that have been developed and must be met to protect the interests of the City.

A. General Liability And Property Damage: With respect to all operations performed by the Contractor, subcontractors, agents or workers, it is the Contractor's responsibility to ensure that general liability insurance coverage, on an occurrence form, provides all major divisions of coverage including, but not limited to:

1. Premises Operations
2. Independent Contractors' Protective
3. Products and Completed Operations
4. Personal Injury Liability
5. Medical Expenses

Coverage limits shall not be less than:

|    |                               |             |
|----|-------------------------------|-------------|
| 1. | General Aggregate             | \$2,000,000 |
| 2. | Products-Completed/Operations | \$2,000,000 |
| 3. | Personal & Advertising Injury | \$1,000,000 |
| 4. | Each Occurrence               | \$1,000,000 |
| 5. | Damage to Rented Premises     | \$ 250,000  |
| 6. | Med. Expense (Any one person) | \$ 5,000    |

**B. Workers' Compensation:** With respect to all operations performed, the Contractor shall carry workers' compensation insurance in accordance with the laws of the State of Vermont and ensure that all subcontractors carry the same workers' compensation insurance for all work performed by them under this contract. Minimum limits for Employer's Liability:

1. Bodily Injury by Accident: \$500,000 each accident
2. Bodily Injury by Disease: \$500,000 policy limit,  
\$500,000 each employee

**C. Automobile Liability:** The Contractor shall carry commercial automobile liability insurance covering all motor vehicles, including owned, non-owned and hired, used in connection with the Contract. Each policy shall provide coverage with a limit not less than: \$1,000,000 - Combined Single Limit for each occurrence.

**D. Umbrella Liability:**

1. \$1,000,000 Each Event Limit

\$1,000,000 General Aggregate Limit

**3. CONFLICT OF INTEREST:** The Contractor shall disclose in writing to the City any actual or potential conflicts of interest or any appearance of a conflict of interest by the Contractor, its employees or agents, or its subcontractors, if any.

**4. PERSONNEL REQUIREMENTS AND CONDITIONS:** A Contractor shall employ only qualified personnel with responsible authority to supervise the work. The City shall have the right to approve or disapprove key personnel assigned to administer activities related to the Contract.

Except with the approval of the City, during the life of the Contract, the Contractor shall not employ:

1. Any City employees who are directly involved with the awarding, administration, monitoring, or performance of the Contract or any project(s) that are the subjects of the Contract.
2. Any City employees so involved within one (1) year of termination of employment with the City.

The Contractor warrants that no company or person has been employed or retained (other than a bona fide employee working solely for the Contractor) to solicit or secure this Contract, and that no company or person has been paid or has a contract with the Contractor to be paid, other than a bona fide employee working solely for the Contractor, any fee, commission, percentage, brokerage fee, gift, or any other consideration, contingent upon or resulting from the award or making of the Contract. For breach or violation of this warranty, the City shall have the right to annul the Contract, without liability to the City, and to regain all costs incurred by the City in the performance of the Contract.

The City reserves the right to require removal of any person employed by a Contractor from work related to the Contract, for misconduct, incompetence, or negligence, in the opinion of the City, in the due and proper performance of Contractor's duties, or who neglects or refuses to comply with the requirements of the Contract.

5. **PERFORMANCE:** Contractor warrants that performance of Work will conform to the requirements of this Contract. Contractor shall use that degree of ordinary care and reasonable diligence that an experienced and qualified provider of similar services would use acting in like circumstances and experience in such matters and in accordance with the standards, practices and procedures established by Contractor for its own business.
6. **RESPONSIBILITY FOR SUPERVISION:** The Contractor shall assume primary responsibility for general supervision of Contractor employees and any subcontractors for all work performed under the Contract and shall be solely responsible for all procedures, methods of analysis, interpretation, conclusions, and contents of work performed under the Contract. The Contractor shall be responsible to the City for all acts or omissions of its subcontractors and any other person performing work under this Contract.
7. **INSPECTION OF WORK:** The City shall, at all times, have access to the Contractor's work for the purposes of inspection, accounting, and auditing, and the Contractor shall provide whatever access is considered necessary to accomplish such inspections. At any time, the Contractor shall permit the City or representative for the City the opportunity to inspect any plans, drawings, estimates, specifications, or other materials prepared or undertaken by the Contractor pursuant to the Contract, as well as any preparatory work, work-in-progress, or completed work at a field site.

Conferences, visits to a site, or an inspection of the work, may be held at the request of any involved party or by representatives of the City.

8. **UTILITIES & ACCESS:** Whenever a facility or component of a private, public, or cooperatively-owned utility will be affected by any proposed construction, the Contractor will counsel with the City and will enter into any necessary contacts and discussions with the affected owners regarding any requirement necessary for revisions of facilities or existing installations, both above and below ground. Any such installations must be completely and accurately exhibited on any detail sheets or plans. The Contractor shall inform the City, in writing, of any such contacts and the results thereof.

The City shall provide the land and/or construction easements for the land upon which the Work under this Contract is to be done, and will, so far as is convenient, permit the Contractor to use as much of the land as is required for the erection of temporary construction facilities and storage of materials, together with the right of access to same, but beyond this, the Contractor shall provide at the Contractor's cost and expense any additional land required.

**9. PROTECTION OF PROPERTY:**

- A. In General: Contractor shall avoid damage, as a result of its operations, to trees, plant life, existing sidewalks, curbs, streets, alleys, pavements, utilities, adjoining property, the work of other contractors, and the property of the City and others. Contractor shall, at its own expense, repair any damage to any property caused by Contractor's operations.
- B. Underpinning and Shoring: Contractor shall become familiar with the requirements of local and state laws applicable to underpinning, shoring and other work affecting adjoining property, and wherever required by law Contractor shall shore up, brace, underpin, secure and protect as may be necessary all foundations and other parts of existing structures adjacent to, adjoining, and in the vicinity of the site, which may be affected in any way by the excavations or other operations connected with the work to be performed under this Contract.
- C. Damage to Utilities: Contractor shall be responsible for all damage to any utility equipment or structures caused by its acts or omissions to act, whether negligent or otherwise, and shall leave the utility equipment or structures in as good condition as they were in prior to the commencement of operations under this contract. However, any utility equipment or structures damaged as a result of any act, or omission to act, of the contractor may, at the option of the city department, utility company, or other party owning or operating the utility equipment or structures damaged, be repaired by the city department, utility company, or other party, and in that event, the cost of repairs shall be borne by Contractor.

**10. PUBLIC RELATIONS:** Throughout the performance of the Contract, the Contractor will endeavor to maintain good relations with the public and any affected property owners. Personnel employed by or representing the Contractor shall conduct themselves with propriety. The Contractor agrees to inform property owners and/or tenants, in a timely manner, if there is need for entering upon private property as an agent of the City, in accordance with 19 V.S.A. § 35 and §.503, to accomplish the work under the Contract. The Contractor agrees that any work will be done with minimum damage to the property and disturbance to the owner. Upon request of the Contractor, the City shall furnish a letter of introduction to property owners soliciting their cooperation and explaining that the Contractor is acting as an agent of the City.

**11. ACKNOWLEDGEMENTS:** Acknowledgment of the City's support must be included in any and all publications, renderings and project publicity, including audio/visual materials developed under this contract.

## 12. APPEARANCES:

- A. Hearings and Conferences: The Contractor shall provide services required by the City and necessary for furtherance of any work covered under the Contract. These services shall include appropriate representation at design conferences, public gatherings and hearings, and appearances before any legislative body, commission, board, or court, to justify, explain and defend its contractual services covered under the Contract.

The Contractor shall perform any liaison that the City deems necessary for the furtherance of the work and participate in conferences with the City, at any reasonable time, concerning interpretation and evaluation of all aspects covered under the Contract.

The Contractor further agrees to participate in meetings with the City and any other interested or affected participant, for the purpose of review or resolution of any conflicts pertaining to the Contract.

The Contractor shall be equitably paid for such services and for any reasonable expenses incurred in relation thereto in accordance with the Contract.

- B. Appearance as Witness: If and when required by the City, the Contractor, or an appropriate representative, shall prepare and appear for any litigation concerning any relevant project or related contract, on behalf of the City. The Contractor shall be equitably paid, to the extent permitted by law, for such services and for any reasonable expenses incurred in relation thereto, in accordance with the Contract.

- 13. RESPONSIBILITY OF COST:** The Contractor shall furnish and pay the cost, including taxes (except tax-exempt entities) and all applicable fees, of all the necessary materials and shall furnish and pay for full time on-site superintendence during any construction activity, labor, tools, equipment, and transportation. The Contractor shall perform all the Work required for the construction of all items listed and itemized under Attachment A (Request for Proposals) and Attachment B (Contractor's Response to Request for Proposals) and in strict accordance with the Contract Documents and any amendments thereto and any approved supplemental plans and specifications. The Contractor agrees to pay all claims for labor, materials, services and supplies and agrees to allow no such charge, including no mechanic's lien, to be fixed on the property of the City.

- 14. PAYMENT PROCEDURES:** The City shall pay or cause to be paid to the Contractor or the Contractor's legal representative payments in accordance with the Contract. When applicable, for the type of payment specified in the Contract, a progress report shall summarize actual costs and any earned portion of fixed fee. All payments will be made in reliance upon the accuracy of all representations made by the Contractor, whether in invoices, progress reports, emails, or other proof of work.

All invoices and correspondence shall indicate the applicable project name, project number and the Contract number. When relevant, the invoice shall further be broken down in detail between projects.

When applicable, for the type of payment specified in the Contract, expenses for meals and travel shall be limited to the current approved in-state rates, as determined by the State of Vermont's labor contract, and need not be receipted. All other expenses are subject to approval by the City and must be accompanied by documentation to substantiate their charges.

No approval given or payment made under the Contract shall be conclusive evidence of the performance of the Contract, either wholly or in part, and no payment shall be construed to be acceptance of defective work or improper materials.

The City agrees to pay the Contractor and the Contractor agrees to accept as full compensation, for performance of all services rendered and expenses encompassed in conformance therewith, the fee specified in the Contract.

**15. DUTY TO INFORM CITY OF CONTRACT DOCUMENT ERRORS:** If Contractor knows, or has reasonable cause to believe, that a clearly identifiable error or omission exists in the Contract Documents, including but not limited to unit prices and rate calculations, Contractor shall immediately give the City written notice thereof. Contractor shall not cause or permit any Work to be conducted which may relate to the error or omission without first receiving written notice by the City that City representatives understand the possible error or omission and have approved of modifications to the Contract Documents or that Contractor may proceed without any modification being made to Contract Documents.

**16. NON-APPROPRIATION:** The obligations of the City under this Contract are subject to annual appropriation by the Burlington City Council. If no funds or insufficient funds are appropriated or budgeted to support continuation of payments due under this Contract, the Contract shall terminate automatically on the first day of the fiscal year for which funds have not been appropriated. The Parties understand and agree that the obligations of the City to make payments under this Contract shall constitute a current expense of the City and shall not be construed to be a debt or a pledge of the credit of the City. The decision whether or not to budget and appropriate funds during each fiscal year of the City is within the discretion of the Mayor and City Council of the City. The City shall deliver written notice to Contractor as soon as practicable of any non-appropriation, and Contractor shall not be entitled to any payment or compensation of any kind for work performed after the City has delivered written notice of non-appropriation.

**17. CHANGE ORDERS & AMENDMENTS:** No changes or amendments to the Contract shall be effective unless documented in writing and signed by authorized representatives of the City and the Contractor. All changes affecting the Project's construction cost, length of time, or modifications of the terms or conditions of the Contract, must be authorized by means of a written Contract Change Order which is mutually agreed to by the City and Contractor. The Contract Change Order will include extra Work, Work for which quantities have been altered from those shown in the Bid Schedule, as well as decreases or increases in the quantities of installed units from those shown in the Bid Schedule because of final measurements. All changes must be recorded on a Contract Change Order (which form is part of these Contract Documents) and fully executed before they can be included in a partial payment estimate.

Changes for Work, quantities, and/or conditions will include any respective time adjustment, if justified. Time adjustments will require an updated Project Schedule with the Change Order.

- 18. EXTENSION OF TIME:** The Contractor agrees to prosecute the work continuously and diligently, and no charges or claims for damages shall be made by the Contractor for delays or hindrances, from any cause whatsoever, during the progress of any portion of services specified in the Contract. The Contractor may request an extension of time for such delays or hindrances, if any.

Time extensions may be granted by amendment only for excusable delays, such as delays beyond the control of the Contractor and without the fault or negligence of the Contractor.

The City may suspend the work or any portion thereof for a period of not more than ninety (90) days at its discretion or such further time as agreed by the Contractor. The Contractor will be allowed an extension of contract time directly attributable to any suspension.

**19. PUBLIC HEALTH EMERGENCY:**

**A. Compliance with Mandates and Guidance:** The Contractor is advised that public health emergencies—meaning public health emergencies, as declared by the City, the State of Vermont, or the Federal Government—may introduce significant uncertainty into the project. The Contractor must comply with all local, state, federal orders, directives, regulations, guidance, advisories during a public health emergency. Contractor shall adhere to the below provisions and consider public health emergencies as it develops project schedules and advances the Work.

**B. Enforcement & Stoppage of Work:** Contractor fails to comply with either 1) the approved public health emergency plan, or 2) any local, state, federal orders, directives, regulations, guidance, or advisories during a public health emergency, the City may stop Work under the Contract until such failure is corrected. Such failure to comply shall constitute a breach of the Contract.

Upon stoppage of work, the City may allow Work to resume, at a time determined by the City, under this Contract if such failure to comply is adequately corrected. The City shall have sole discretion in determining if Contractor has adequately corrected its failure to comply with the above.

If Contractor's breach of Contract has not been cured within seven (7) days after notice to stop Work from the City, then City may terminate this Contract, at its discretion.

**C. City Liability Relating to Potential Delays:** If a public health emergency is declared, the City will not be responsible for any delays related to the sequence of operations or any

expenses or losses incurred as a result of any delays. Any delays related to a public health emergency will be excusable, but will not be compensable.

**20. FORCE MAJEURE:** Neither Party to this Contract shall be liable to the other for any failure or delay of performance of any obligation under this Contract to the extent the failure or delay is caused by acts of God, public health emergencies, epidemics, acts of the public enemy, acts of superior governmental authority, weather conditions, riots, rebellion, sabotage, or any other circumstances for which it is not responsible or which is not under its control (“Force Majeure”). To assert Force Majeure, the nonperforming party must prove that a) it made all reasonable efforts to remove, eliminate, or minimize the cause of delay or damage, b) diligently pursued performance of its obligations, c) substantially fulfilled all obligations that could be fulfilled, and d) timely notified the other part of the likelihood or actual occurrence of a Force Majeure event. If any such causes for delay are of such magnitude as to prevent the complete performance of the Contract within two (2) years of the originally scheduled completion date, either Party may by written notice request to amend or terminate the Contract. The suspension of any obligations under this section shall not cause the term of this Contract to be extended and shall not affect any rights accrued under this Contract prior to the occurrence of the Force Majeure. The Party giving notice of the Force Majeure shall also give notice of its cessation.

**21. PAYMENT FOR EXTRA WORK, ADDITIONAL SERVICES OR CHANGES:** The City may, in writing, require or agree to changes, or additions to or deletions from the originally contemplated scope of work.

The value of such changes, to the extent not reflected in other payments to the Contractor, shall be incorporated in an amendment and be determined by mutual agreement, by one or more of the following:

1. Fixed Price. By a price that is not subject to any adjustment on the basis of the Contractor’s expenses experienced in performing the work. The Contractor is fully responsible for all costs and resulting profit or loss.
2. Rate Schedule. By unit prices designated in the Contract, or by unit prices covered under any subsequent contracts.
3. Actual Cost. By amounts determined on the basis of actual costs incurred, as distinguished from forecasted expenditures.

No changes for which additional fee payment is claimed shall be made unless pursuant to a written order from the City, and no claim for payment shall be valid unless so ordered.

The Contractor agrees to maintain complete and accurate records of all change work, in a form satisfactory to the City. The City reserves the right to audit the records of the Contractor related to any extra work or additional services. Any such services rendered shall be subject, in all other

respects, to the terms of the Contract. When changes are so ordered, no additional work shall be performed by the Contractor until a Contract amendment has been fully executed, unless written notice to proceed is issued by the City. Any claim for extension of time that may be necessitated as a result of extra work or additional services and changes shall be given consideration and evaluated insofar as it directly relates to the change.

- 22. FAILURE TO COMPLY WITH TIME SCHEDULE:** If the City is dissatisfied because of slow progress or incompetence in the performance of the Work in accordance with the schedule for completion of the various aspects of construction, the City shall give the Contractor written notice in which the City shall specify in detail the cause of dissatisfaction. Should the Contractor fail or refuse to remedy the matters complained of within five days after the written notice is received by the Contractor, the City shall have the right to take control of the Work and either make good the deficiencies of the Contractor itself or direct the activities of the Contractor in doing so, employing such additional help as the City deems advisable. In such events, the City shall be entitled to collect from the Contractor any expenses in completing the Work. In addition, the City may withhold from the amount payable to the Contractor an amount approximately equal to any interest lost or charges incurred by the City for each calendar day that the Contractor is in default after the time of completion stipulated in the Contract Documents.
- 23. RETURN OF MATERIALS:** Contractor agrees that at the expiration or termination of this Contract, it shall return to City all materials provided to it during its engagement on behalf of City.
- 24. ACCEPTANCE OF FINAL PAYMENT; RELEASE:** Contractor's acceptance of the final payment shall be a release in full of all claims against the City or its agents arising out of or by reason of the Work. Any payment, however, final or otherwise, shall not release the Contractor or its sureties from any obligations under the Contract Documents or any performance or payment bond.
- 25. OWNERSHIP OF THE WORK:** The Contractor agrees that the ownership of all studies, data sheets, survey notes, subsoil information, drawings, tracings, estimates, specifications, proposals, diagrams, calculations, EDM and other material prepared or collected by the Contractor, hereafter referred to as "instruments of professional service", shall become the property of the City as they are prepared and/or developed in the course of the Contract. The Contractor agrees to allow the City access to all "instruments of professional service" at any time. The Contractor shall not copyright any material originating under the Contract without prior written approval of the City. No publications or publicity of the work, in part or in total, shall be made without the express written agreement of the City, except that Contractor may in general terms use previously developed instruments of professional service to describe its abilities for a project in promotional materials.
- 26. PROPRIETARY RIGHTS:** The Parties under the Contract hereby mutually agree that, if patentable discoveries or inventions should result from work performed by the Contractor under the Contract, all rights accruing from such discoveries or inventions shall be the sole property of the Contractor. The Contractor, however, agrees to and does hereby grant to the

City an irrevocable, nonexclusive, non-transferable, and royalty-free license to the manufacture, use, and disposition of any discovery or invention that may be developed as a part of the Work under the Contract.

- 27. PUBLIC RECORDS:** The Contractor understands that any and all records related to and acquired by the City, whether electronic, paper, or otherwise recorded, are subject to the Vermont Public Records Act and that the determination of how those records must be handled is solely within the purview of City. The Contractor shall identify all records that it considers to be trade secrets as that term is defined by subsection 317(c)(9) of the Vermont Public Records Act and shall also identify all other records it considers to be exempt under the Act. It is not sufficient to merely state generally that the record is proprietary or a trade secret or is otherwise exempt. Particular records, pages or section which are believed to be exempt must be specifically identified as such and must be separated from other records with a convincing explanation and rationale sufficient to justify each exemption from release consistent with Section 317 of Title 1 of the Vermont Statutes Annotated.
- 28. RECORDS RETENTION AND ACCESS:** The Contractor agrees to retain, in its files, and to produce to the City—within the time periods requested—all books, documents, electronic data media (EDM), accounting records, and other records produced or acquired by the Contractor in the performance of this Contract which are related to the City, at any time during this Contract and for a period of at least three (3) years after its completion or termination. In addition, if any audit, claim, or litigation is commenced before the expiration of that three (3) year period, the records shall be retained until all related audits, claims, or litigation are resolved. The Contractor further agrees that the City shall have access to all the above information for the purpose of review and audit during the Contract period and any time within the aforementioned retention period. Copies of all of the above referenced information shall be provided to the City, if requested, in the format in which the records were obtained, created, or maintained, such that their original use and purpose can be achieved. Contractor, subcontractors, or their representatives performing work related to the Contract, are responsible to ensure that all data and information created or stored on EDM is secure and can be duplicated and used if the EDM mechanism is subjected to power outage, obsolescence, or damage.
- 29. WARRANTY:** In addition to any warranty provided by the manufacturer or distributor, Contractor guarantees the Work performed, and all materials or equipment furnished, to be free from defects in material and workmanship for a minimum period of one (1) year from the date of the City's acceptance of completion. The Contractor's warranty is not intended and shall not be interpreted as a limitation upon the City's rights or a waiver of manufacturer and distributor warranties, any subcontractor warranties, or any other warranties provided in connection with the Work.

Contractor, at its own expense, shall make any repairs, or replacement necessary to correct these defects to the satisfaction of the City.

This warranty of material and workmanship applies only:

1. To the property only as long as it remains in the possession of the City.

2. To the Work that has not been subject to accident, misuse, or abuse by someone other than the Contractor.
3. To the Work that has not been modified, altered, defaced, or had repairs made or attempted by someone other than the Contractor.
4. If the Contractor is immediately notified in writing within ten (10) days of first knowledge of the defect by the City.
5. If the Contractor is given the first opportunity to make any repairs, replacements, or corrections to the defective construction at no cost to the City within a reasonable period of time.

Under no circumstances shall Contractor be liable by virtue of this warranty or otherwise for damage to any person or property whatsoever for any special, indirect, secondary or consequential damages of any nature however arising out of the use or inability to use because of the construction defect.

If the Contractor is unable, after receipt of two (2) written notices given to Contractor by the City, to successfully repair or replace the labor, equipment, or materials within six (6) months of the second notice, then the District's repair and replace warranty shall be deemed to have failed and the City's rights and remedies shall not be limited by the provisions of this section.

**30. CONTRACT DISPUTES:** In the event of a dispute between the parties to this Contract, each party will continue to perform its obligations unless the Contract is terminated in accordance with these terms.

**31. SETTLEMENTS OF MISUNDERSTANDINGS:** To avoid misunderstandings and litigation, it is mutually agreed by all Parties that the Head of Burlington Parks, Recreation & Waterfront shall act as referee on all questions arising under the terms of the Contract and that the decision of the Head of Parks, Recreation & Waterfront in such cases shall be binding upon both Parties.

**32. CITY'S OPTION TO TERMINATE:** The Contract may be terminated in accordance with the following provisions, which are not exclusive:

- A. Termination for Convenience: At any time prior to completion of services specified under the Contract, the City may terminate the Contract for any reason by submitting written notice via certified or registered mail to the Contractor, not less than fifteen (15) days prior to the termination date, of its intention to do so. If the termination is for the City's convenience, payment to the Contractor will be made promptly for the amount of any fees earned to the date of the notice of termination and costs of materials obtained in preparation for Work but not yet installed or delivered, less any payments previously made. However, if a notice of termination is given to a Contractor prior to completion of twenty (20) percent of the estimated services, as set forth in the approved Work Schedule and Progress Report,

the Contractor will be reimbursed for that portion of any reasonable and necessary expenses incurred to date of the notice of termination that are in excess of the amount earned under its approved fee to the date of said termination. Such requests for reimbursement shall be supported with factual data and shall be subject to the City's approval. The Contractor shall make no claim for additional compensation against the City by reason of such termination.

**B. Termination for Cause:**

- i. Breach: Contractor shall be in default if Contractor fails in any manner to fully perform and carry out each and all conditions of this Contract, including, but not limited to, Contractor's failure to begin or to prosecute the Work in a timely manner or to make progress as to endanger performance of this Contract; failure to supply a sufficient number of properly skilled employees or a sufficient quantity of materials of proper quality; failure to perform the Work unsatisfactorily as determined by the City; failure to neglect or refuse to remove materials; or in the event of a breach of warranty with respect to any materials, workmanship, or performance guaranty. Contractor will not be in default for any excusable delays as provided in Sections 18-20.

The City may give Contractor written notice of such default. If Contractor does not cure such default or provide a plan to cure such default which is acceptable to the City within the time permitted by the City, then the City may terminate this contract for cause.

- ii. Dishonest Conduct: If Contractor engages in any dishonest conduct related to the performance or administration of this Contract then the City may immediately terminate this contract.
- iii. Cover: In the event the City terminates this contract as provided in this section, the City may procure, upon such terms and in such manner as the City may deem appropriate, services similar in scope and level of effort to those so terminated, and Contractor shall be liable to the City for all of its costs and damages, including, but not limited to, any excess costs for such services, interest, or other charges the City incurs to cover.
- iv. Rights and Remedies Not Exclusive: The rights and remedies of the City provided in this section shall not be exclusive and are in addition to any other rights and remedies provided by law or under this Contract.

**33. GENERAL COMPLIANCE WITH LAWS:** The Contractor and any subcontractor approved under this Contract shall comply with all applicable Federal, State and local laws, including but not limited to the Burlington Livable Wage Ordinance, the Non-Outsourcing Ordinance, and the Union-Deterrence Ordinance and shall provide the required certifications

attesting to compliance with these ordinances (see attached ordinances and certifications).

- 34. SAFETY REQUIREMENTS:** The Contractor shall comply with all pertinent provisions of the Occupational Safety and Health Administration (OSHA) and any VOSHA (Vermont OSHA) Safety and Health requirements, including the provision and use of appropriate safety equipment and practices.

The Contractor, and not the City, shall be responsible for the safety, efficiency, and adequacy of Contractor's or its subcontractors' plant, appliances, equipment, vehicles, and methods, and for any damages, which may result from their failure or their improper construction, maintenance or operation.

- 35. CIVIL RIGHTS AND EQUAL EMPLOYMENT OPPORTUNITY:** During performance of the Contract, the Contractor will not discriminate against any employee or applicant for employment because of religious affiliation, race, color, national origin, place of birth, ancestry, age, sex, sexual orientation, gender identity, marital status, veteran status, disability, HIV positive status, crime victim status, or genetic information. Contractor, and any subcontractors, shall comply with any Federal, State, or local law, statute, regulation, executive order, or rule that applies to it or the services to be provided under this contract concerning equal employment, fair employment practices, affirmative action, or prohibitions on discrimination or harassment in employment.

- 36. CHILD SUPPORT PAYMENTS:** By signing the Contract, the Contractor certifies, as of the date of signing the Contract, that the Contractor (a) is not under an obligation to pay child support; or (b) is under such an obligation and is in good standing with respect to that obligation; or (c) has agreed to a payment plan with the Vermont Office of Child Support Services and is in full compliance with that plan. If the Contractor is a sole proprietorship, the Contractor's statement applies only to the proprietor. If the Contractor is a partnership, the Contractor's statement applies to all general partners with a permanent residence in Vermont. If the Contractor is a corporation, this provision does not apply.

- 37. TAX REQUIREMENTS:** By signing the Contract, the Contractor certifies, as required by law under 32 VSA, Section 3113, that under the pains and penalties of perjury, the Contractor is in good standing with respect to payment, or in full compliance with a plan to pay, any and all taxes due the State of Vermont as of the date of signature on the Contract.

**38. INDEMNIFICATION:**

- A. Indemnification by Contractor:** Except for the gross negligence or willful misconduct by the City, or any of its boards, officers, agents, employees, assigns and successors in interest, contractor undertakes and agrees to defend, indemnify and hold harmless the City and any of its boards, officers, agents, employees, assigns, and Successors in Interest from and against all suits and causes of action, claims, losses, demands and expenses, including, but not limited to, attorney's fees (both in house and outside counsel) and cost of litigation (including all actual litigation costs incurred by the City, including but not limited to, costs of experts and consultants), damages or liability of any nature

whatsoever, for death or injury to any person, including Contractor's employees and agents, or damage or destruction of any property of either party hereto or of third parties, arising in any manner by reason of the negligent acts, errors, omissions or willful misconduct incident to the performance of this Contract by Contractor or its subcontractors of any tier.

- B. Notice of Claims & City's Right to Participate:** If the City, its officers, agents, or employees are notified of any claims asserted against it to which this indemnification provision may apply, the City shall immediately thereafter notify the Contractor in writing that a claim to which the indemnification provision may apply has been filed. Contractor shall immediately retain counsel and otherwise provide a complete defense against the entire claim or suit. The City retains the right to participate, at its own expense, in the defense of any claim, and to approve all proposed settlements of claims to which this provision applies.
- C. City's Rights and Remedies:** Rights and remedies available to the City under this provision are cumulative of those provided for elsewhere in this Contract and those allowed under the laws of the United States and the State of Vermont.
- D. No Indemnification by City:** Under no conditions shall the City be obligated to indemnify the Contractor or any third party, nor shall the City be otherwise liable for expenses or reimbursement including attorney's fees, collection costs, or other costs of the Contractor or any third party.

**39. NO GIFTS OR GRATUITIES:** The Contractor shall not make any payment or gift or donation of substantial value to any elected official, officer, employee, or agent of the City during the term of this Contract.

**40. ASSIGNMENT:** Contractor shall not sublet or assign this Work, or any part of it, without the written consent of the City. If any subcontractor is approved, Contractor shall be responsible and liable for all acts or omissions of that subcontractor for any Work performed. If any subcontractor is approved, Contractor shall be responsible to ensure that the subcontractor is paid as agreed and that no lien is placed on any City property.

**41. TRANSFERS, SUBLETTING, ASSIGNMENTS, ETC:** Contractor shall not assign, sublet, or transfer any interest in the work, covered by this Contract, without prior written consent of the City and further, if any subcontractor participates in any work involving additional services, the estimated extent and cost of the contemplated work must receive prior written consent of the City. The approval or consent to assign or sublet any portion of the work, shall in no way relieve the Contractor of responsibility for the performance of that portion of the work so transferred. The form of the subcontractor's contract shall be as developed by the Contractor and approved by the City. The Contractor shall ensure that insurance coverage exists for any operations to be performed by any subcontractor as specified in the insurance requirements section of this Contract.

The services of the Contractor, to be performed under the Contract, shall not be transferred without written authorization of the City. Any authorized sub-contracts shall contain all of the same provisions contained in and attached to the original Contract with the City.

- 42. CONTINUING OBLIGATIONS:** The Contractor agrees that if because of death, disability, or other occurrences, it becomes impossible to effectively perform its services in compliance with the Contract, neither the Contractor nor its surviving members shall be relieved of their obligations to complete the Contract unless the City agrees to terminate the Contract because it determines that the Contractor is unable to satisfactorily execute the Contract.
- 43. INTERPRETATION & IMPLEMENTATION:** Provisions of the Contract shall be interpreted and implemented in a manner consistent with each other and using procedures that will achieve the intent of both Parties.
- 44. ARM'S LENGTH:** This Contract has been negotiated at arm's length, and any ambiguity in any of its terms or provisions shall be interpreted in accordance with the intent of the Parties and not against or in favor of either the City or Contractor.
- 45. RELATIONSHIP:** The Contractor is an independent contractor and shall act in an independent capacity and not as officers or employees of the City. To that end, the Contractor shall determine the method, details, and means of performing the work, but will comply with all legal requirements in doing so. The Contractor shall provide its own tools, materials, or equipment. The Parties agree that neither the Contractor nor its principal(s) or employees are entitled to any employee benefits from the City. Contractor understands and agrees that it and its principal(s) or employees have no right to claim any benefits under the Burlington Employee Retirement System, the City's worker's compensation benefits, health insurance, dental insurance, life insurance, or any other employee benefit plan offered by the City. The Contractor agrees to execute any certifications or other documents and provide any certificates of insurance required by the City and understands that this Contract is conditioned on its doing so, if requested.

The Contractor understands and agrees that it is responsible for the payment of all taxes on the above sums and that the City will not withhold or pay for Social Security, Medicare, or other taxes or benefits or be responsible for any unemployment benefits.

- 46. CHOICE OF LAW:** Vermont law, and rules and regulations issued pursuant thereto, shall be applied in the interpretation, execution, and enforcement of this Contract. Any provision included or incorporated herein by reference which conflicts with said laws, rules, and regulations shall be null and void. Any provision rendered null and void by operation of this provision shall not invalidate the remainder of this Contract to the extent capable of execution.
- 47. JURISDICTION:** All suits or actions related to this Contract shall be filed and proceedings held in the State of Vermont.
- 48. BINDING EFFECT AND CONTINUITY:** This Contract shall be binding upon and shall inure to the benefit of the Parties, their' respective heirs, successors, representatives, and assigns. If a dispute arises between the Parties, each Party will continue to perform its

obligations under this Contract during the resolution of the dispute, until the Contract is terminated in accordance with its terms.

- 49. SEVERABILITY:** The invalidity or unenforceability of any provision of this Contract or the Contract Documents shall not affect the validity or enforceability of any other provision, which shall remain in full force and effect, provided that the Parties can continue to perform their obligations under this Contract in accordance with the intent of this Contract.
- 50. ENTIRE CONTRACT & AGREEMENT:** This Contract, including the Contract Documents, constitutes the entire Contract, agreement, and understanding of the Parties with respect to the subject matter of this Contract. Prior or contemporaneous additions, deletions, or other changes to this Contract shall not have any force or effect whatsoever, unless embodied herein.
- 51. APPENDICES:** The City may attach, to these specifications, appendices containing various forms and typical sample sheets for guidance and assistance to the Contractor in the performance of the work. It is understood, however, that such forms and samples may be modified, altered, and augmented from time to time by the City as occasions may require. It is the responsibility of the Contractor to ensure that they have the latest versions applicable to the Contract.
- 52. NO THIRD PARTY BENEFICIARIES:** This Contract does not and is not intended to confer any rights or remedies upon any person or entity other than the Parties. Enforcement of this Contract and all rights and obligations hereunder are reserved solely to the Parties. Any services or benefits which third parties receive as a result of this Contract are incidental to this Contract, and do not create any rights for such third parties.
- 53. WAIVER:** A Party's failure or delay in exercising any right, power, or privilege under this Contract, whether explicit or by lack of enforcement, shall not operate as a waiver, nor shall any single or partial exercise of any right, power, or privilege preclude any other or further exercise of such right, power, or privilege.

**Attachment D:  
Burlington Livable Wage Ordinance Certification**

DRAFT



**Attachment E:  
Burlington Outsourcing Ordinance Certification**

DRAFT

Certification of Compliance with the City of Burlington's Outsourcing Ordinance

I, Chester J. Layman, on behalf of  
PC Construction Company (Contractor) and in connection with the  
Memorial Auditorium Roof Framing Stabilization

\_\_\_\_\_ [project], hereby certify under oath that (1) Contractor shall comply with the City of Burlington's Outsourcing Ordinance (Ordinance §§ 21-90 – 21-93); (2) as a condition of entering into this contract or grant, Contractor confirms that the services provided under the above-referenced contract will be performed in the United States or Canada.

Dated at 193 Tilley Drive, South Burlington, Vermont this 19th day of October, 2022.

By:   
Duly Authorized Agent

Subscribed and sworn to before me:

  
Notary

Karyn Carstensen  
My commission expires January 31, 2023  
Credential # 157.0003965



**Attachment F:  
Burlington Union Deterrence Ordinance Certification**

DRAFT

**Attachment G:  
Contractor's Certificate of Insurance**

DRAFT